

# GRADALL® XL 4210<sup>III</sup>

INDUSTRIAL  
MAINTENANCE  
MACHINE

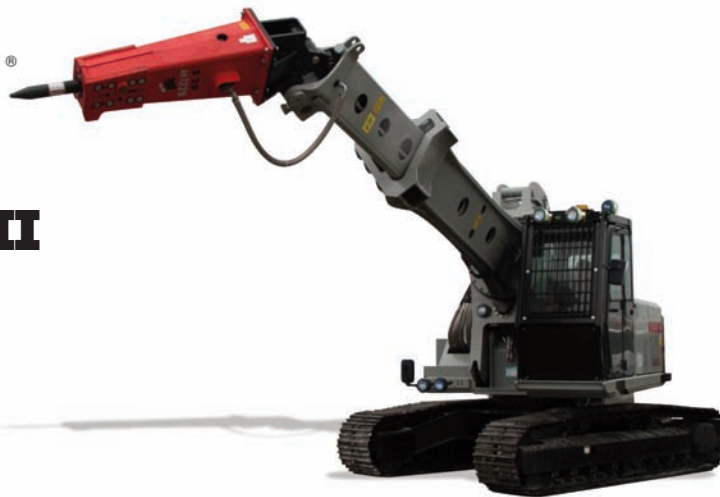

XL 4210<sup>III</sup>

## SPECIFICATIONS

### Upperstructure Engine

Detroit Diesel OM904 Tier-3 diesel, 4 cycle, inline 4 cylinder, liquid cooled, electronic controlled. Vertical canister style lube filter attached to engine. Remote mount primary fuel/water separator.

Gross Rating: 173HP @ 2200 RPM (129kW)  
498 ft. lb. Torque @ 1200-1600 RPM (675Nm)  
Net Rating: 153 HP @ 2200 RPM (114kW)

Variable viscous fan clutch system. Vertical stacked hyd. oil cooler, charge air cooler and radiator.

Maximum slope: 30°

12 volt starter, 100 amp alternator, two SAE #C31-S 1000 CCA batteries, two-stage dry type air cleaner with centrifugal precleaner and safety element. Evacuator valve and service indicator.

Fuel tank capacity: 82 gallons (310 L).

### Hydraulic System

#### PUMPS

One load-sensing, axial piston pump; oil flow 0-105 GPM (0-435 L/min).

Gear pump, 6GPM (23 L/min)

#### SYSTEM MONITOR

Electronic monitor in cab indicates low hydraulic fluid level, high hydraulic fluid temperature, system working pressure, system pilot pressure.

#### SYSTEM SPECIFICATIONS

#### Four cylinders

- 1 tool: 5.0" ID, 30" rod (127 mm x 76 mm), 25.9" (658 mm) stroke.
- 2 hoist: 4.25" ID, 3.15" rod (108 mm x 80 mm), 31.0" (787 mm) stroke.
- 1 telescope: 3.5" ID, 2.559" rod (89 mm x 65 mm), 12'6" (3.81 m) stroke.

#### Four hydraulic motors

Swing, 64hp (48 kW); tilt, 50 hp (37 kW); 2 propel motors, 120 hp (89 kW) each.

#### Operating pressures:

Hoist.....	4,900 psi	(331 BAR)
Tilt .....	4,900 psi	(331 BAR)
Swing .....	4,200 psi	(290 BAR)
Tool.....	4,900 psi	(331 BAR)
Telescope .....	4,900 psi	(331 BAR)
Propel.....	4,900 psi	(331 BAR)
Pilot System .....	550 psi	(38 BAR)

#### Oil Capacity

Reservoir system 65 gallons (246 L).  
Pressurized reservoir with visual oil level gauges.

#### Filtration System

10 micron return filter, 10 micron pilot filter.

Fin and tube-type oil cooler with thermal by-pass and relief valves.

Pressure-compensated, load-sensing valves with circuit reliefs in all circuits.

### Upperstructure Cab

All-weather cab with tinted safety glass windows, acoustical lining, four-way adjustable operator's seat, AM/FM radio, filtered fresh air heater, defroster, and A/C. Front window has heat-resistant glass. Rearview mirrors on right and left sides. Standard equipment includes swing lights.

### Crawler Drive

Dual range, high torque piston motor powers each track. Three-stage planetary drive with integral speed limiting valve and automatic spring-set/hydraulic release wet disc parking brake.

**Travel Speed:** on flat, level surface:

High Speed: 3.4 mph (5.5 km/h)

Low Speed: 1.9 mph (3.1 km/h)

Automatic two-speed control shifts crawler drive into low speed under difficult travel conditions. Manual override switch for loading the machine for transport.

#### Gradeability:

58%, limited by engine lubrication requirements.

#### Drawbar Pull

38,324 lb (170 kN)

#### Individual Track Control

Tracks counter-rotate to pivot machine about the swing centerline. Electronically operated travel alarm signals crawler movement in either direction.

### Controls

Two electronic joysticks (hoist and bucket, telescope and swing), one rocker switch (tilt) control upperstructure. Joysticks mounted on arm pods, independently adjustable for individual operator comfort and convenience.

Quick change joystick pattern switch located on instrumental panel. Joysticks are self-centering; when controls are released, power for movement disengages and swing and tilt brake set automatically.

Two electric foot pedals (with handles) control crawler travel speed and direction, crawler steering, and crawler brakes. Toggle switch on arm pod allows selection of two crawler speed ranges.

#### Engine Controls and Instrumentation

Key operated ignition/starter switch, throttle, and main battery disconnect switch. Air cleaner condition indicator. Electronic monitor indicates fuel level, low battery charge, lube oil pressure, high coolant temperature, engine rpm, and engine hours. Fuel saving auto idle feature sends engine rpm to idle when control circuits are in neutral for seven seconds.

### Swing

Priority swing circuit with axial piston motor. Planetary transmission.

Swing speed: 7.0 rpm.

#### Swing Brake

Automatic spring-set/hydraulic release wet disc parking brake. Dynamic braking is provided by the hydraulic system.

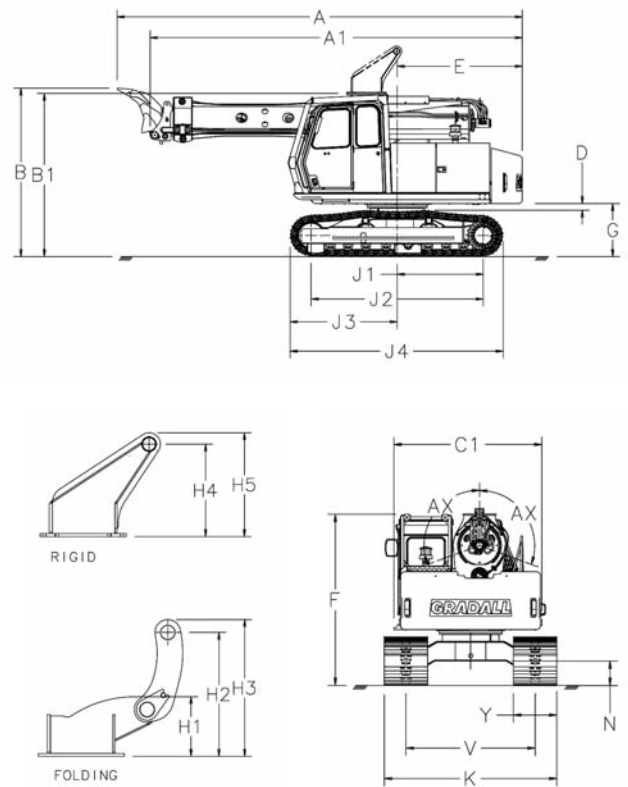
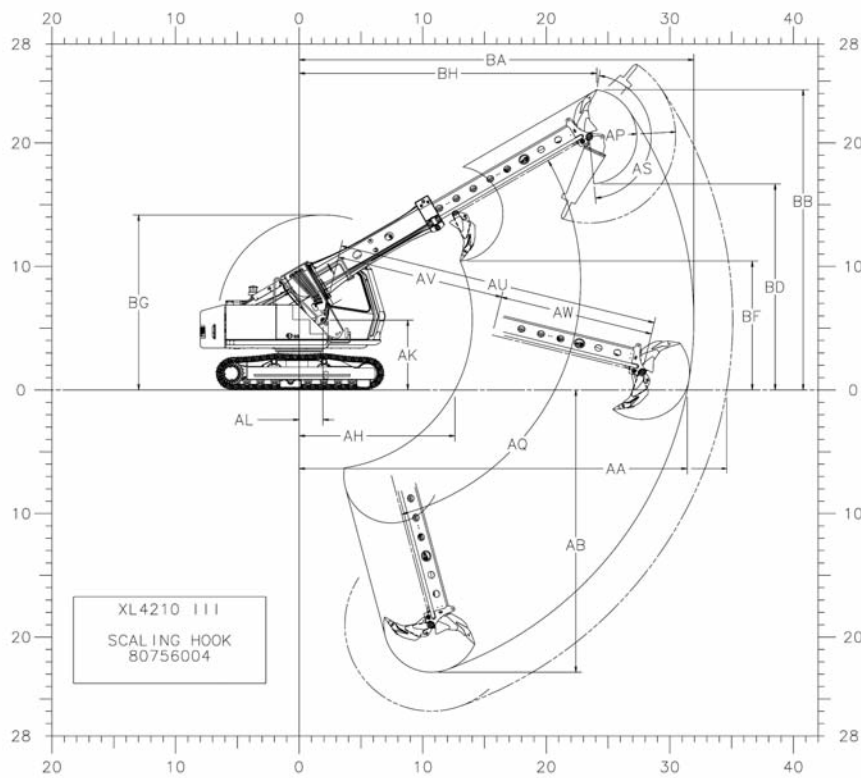

## Dimensions

- A** Overall length with attachment open: 25'11" (7.9)
- A1** Overall length without attachment: 23'10" (7.3)
- B** Overall height with attachment open: 10'9" (3.3)
- B1** Overall height without attachment: 10'5" (3.2)
- C1** Width of upperstructure: 9'0" (2.7)
- D** Minimum clearance, upperstructure to undercarriage: 5" (130mm)
- E** Swing clearance, rear of upperstructure: 8'0" (2.4)
- F** Top of cab guard to groundline: 10'5" (3.2)
- G** Clearance, upperstructure to groundline: 3'5" (1.0)
- H1** Height of optional folding lift yoke lowered: 1'9" (0.5)
- H2** Height of pin of optional folding lift yoke: 3'7" (1.1)
- H3** Overall height of optional folding lift yoke: 4'0" (1.2)
- H4** Height to pin of optional rigid lift yoke: 2'8" (0.8)
- H5** Overall height of optional rigid lift yoke: 3'0" (0.9)
- J1** Axis of rotation to centerline of drive sprockets: 5'1" (1.7)
- J2** Nominal distance between centerlines of drive sprockets and idlers: 11'0" (3.4)
- J3** Axis of rotation to end of track assembly: 6'10" (2.1)
- J4** Nominal overall length of track assembly: 13'8" (4.2)
- K** Width of crawler (standard): 10'6" (3.2)  
Width of crawler (optional): 9'10" (3.0)
- N** Ground clearance (per SAE J1234): 18" (454 mm)
- V** Track gage, roller centerline to roller centerline: 7'10" (2.4)
- Y** Width of crawler track assembly (standard): 31'5" (800mm)  
Width of crawler track assembly (optional): 23'6" (600mm)
- AA** Maximum radius at groundline (Scaling Hook): 31'5" (9.6)  
Maximum radius at groundline (S-29 Hammer): 34'7" (10.5)
- AB** Maximum depth: 22'10" (7.0)
- AH** Minimum radius at groundline: 12'7" (3.8)
- AK** Boom pivot to groundline: 5'8" (1.7)
- AL** Boom pivot to axis of rotation: 1'11" (585 mm)
- AP** Attachment tooth radius (Scaling Hook): 3'10" (1.2)  
Attachment bit radius (S-29 Hammer): 7'0" (2.1)
- AQ** Boom pivot angle: 30° Up and 75° Down
- AS** Attachment pivot angle: 165°
- AU** Maximum telescoping boom length (boom pivot to attachment pivot): 26'1" (8.0)
- AV** Minimum telescoping boom length (boom pivot to attachment pivot): 13'7" (4.1)
- AW** Telescoping boom travel: 12'6" (3.8)
- AX** Bucket tilt angle (continuous): 360°
- BA** Maximum radius of working equipment: 31'11" (9.7)
- BB** Maximum height of working equipment: 24'4" (7.4)
- BD** Minimum clearance of attachment with pivot at maximum height: 16'8" (5.1)
- BF** Minimum clearance of attachment at maximum boom height: 10'5" (3.2)
- BG** Maximum height of working equipment with attachment below groundline: 14'2" (4.3)
- BH** Radius of attachment tooth at maximum height: 24'1" (7.3)

Metric units are meters (m) unless noted.

# GRADALL®

Gradall Industries Inc.  
406 Mill Ave. SW, New Philadelphia, Ohio 44663  
Phone: 330-339-2211 Fax: 330-339-8468  
www.gradall.com



Certified ISO 9001

## Function Forces

- Rated Boom Force:**  
22,075 lb (98.2 kN)
- Rated Ripper Tooth Force:**  
25,405 lb (113 kN)
- Boom Rotating Torque:**  
25,800 ft•lb (34,980 N•m)
- Boom Rotating Speed:**  
7.0 RPM

## Weight

Approximate working weight with hammer, fuel tank half full and no operator.

Pad Size	Weight	Bearing Pressure
31.5" 800mm	48,500 lb (22,000 kg)	5.8 psi (40.2 kPa)